



Package	Tape Width	Reel Size	Pitch	Packaging Quantity			Tape Orientation	OPN Suffix
	mm	inch	mm	Reel	Inner Box	Carton	Feed Direction	
				kpcs	kpcs	kpcs		

13 8

SOP-8-
Dual

12

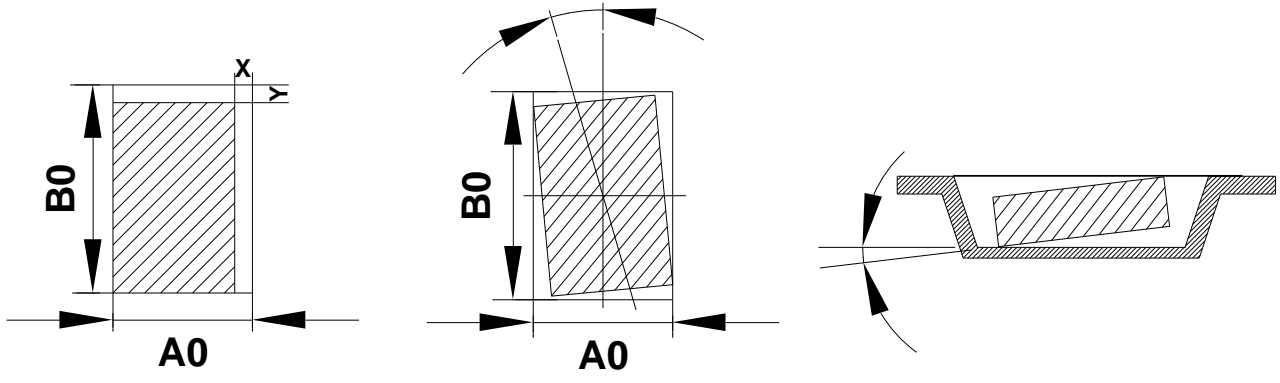

Tape width	8,12mm
X(mm)	0.5
Y(mm)	0.5

Maximum Component Rotation		
Tape width	Top View	Side View
Mm		s
8 12	20	20

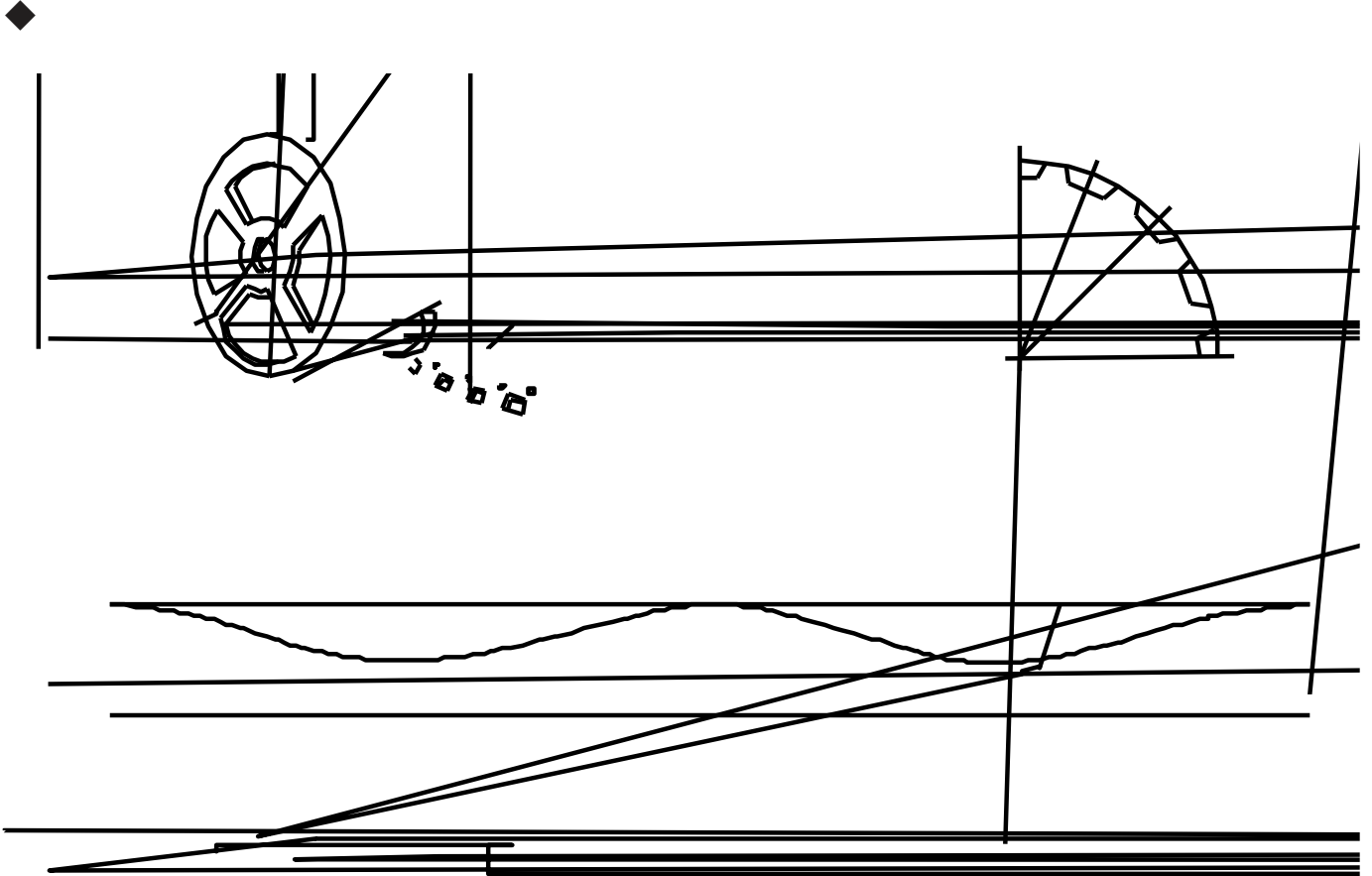

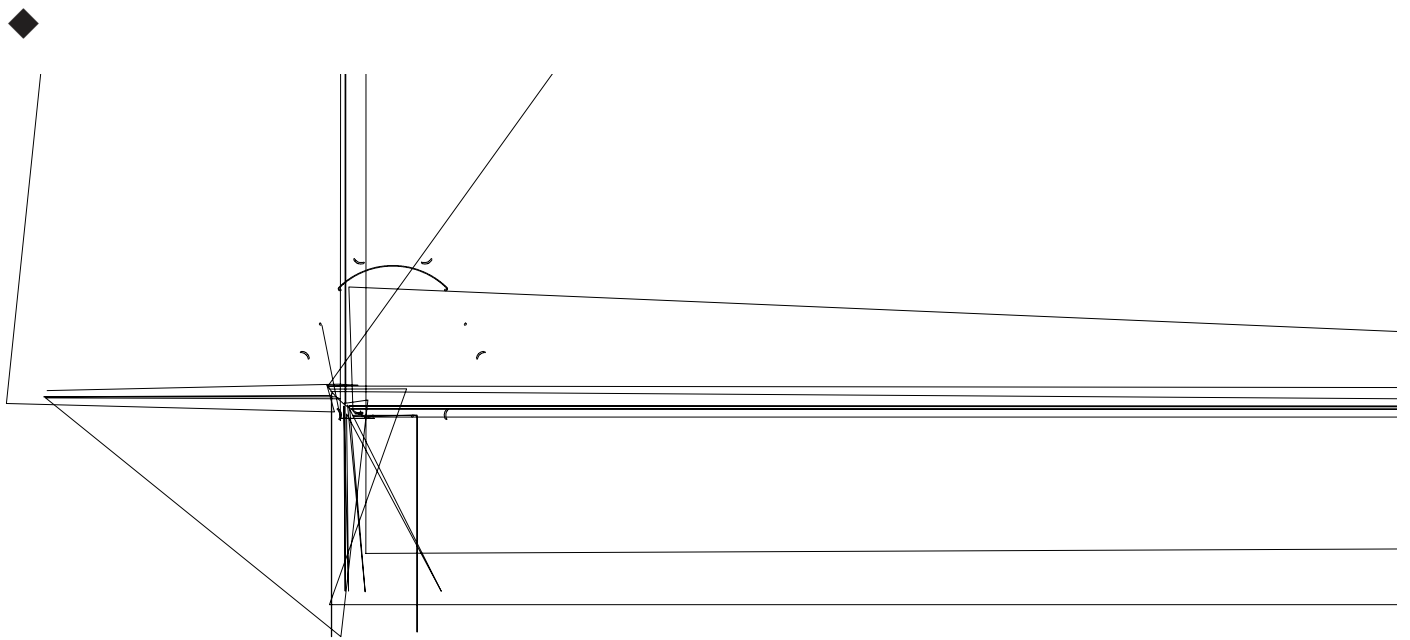
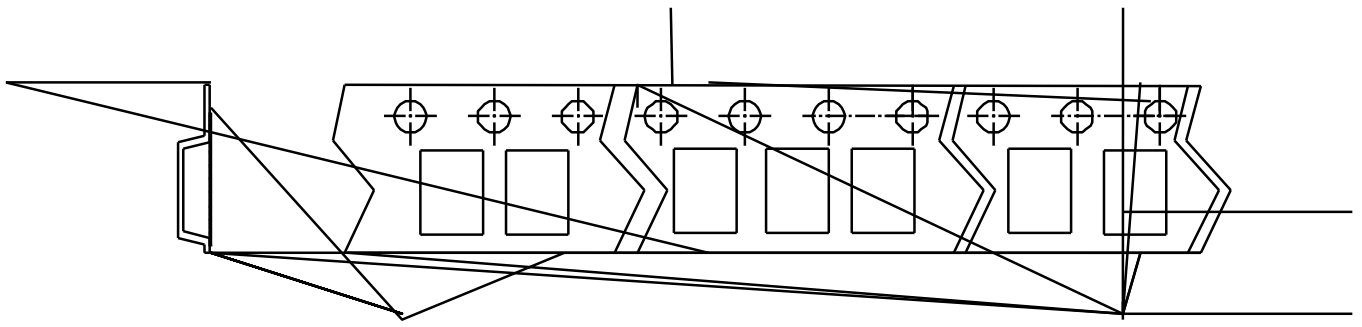

Tape	A(mm)	B(mm)	C(mm)	D(mm)	N(mm)	G(mm)	T(mm)
13 寸 12mm	331	2.76	13.75	21.97	99.06	12.8	16.7
(Tolerance)	±2	±0.2	±0.2	±1.0	±2.0	+2.0	无阻碍

